

Howak **security**

An investment in Firearm safety

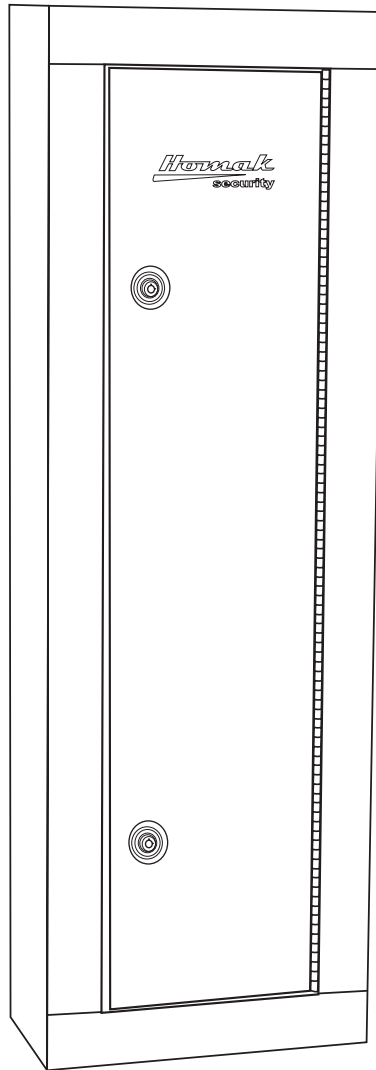

OWNER'S MANUAL **and** **Operating Instructions** **6 Gun Security Cabinet**

CAUTION:

Read all Instructions and Safety tips before using this product.
Lisez toutes les instructions et la sûreté incline avant d'employer ce produit.
Lea todas las instrucciones y la seguridad inclina antes de usar este producto.

MECHANICAL ASSEMBLY

Inside the rifle door you will find the following items:

- Wall mounting kit
- Foam components
- Shelf
- Lock Key set
- Barrel Rest Kit

1. Install the cabinet

Locate the four washers and screws. Place the cabinet in a suitable location. Using the screws provided with the washers as shown, locate and fasten the cabinet to the wall. The cabinet screw holes are 16 inches apart.

NOTE: This cabinet is not designed to be used without securing it to a wall or other surface. IT MAY TIP OVER!

2. Install the shelves

Locate the two steel shelves. Push them down to insure they are installed properly.

3. Foam Components

The foam parts are shown below. Each part has been designed to fit into the cabinet in a particular place. Carefully remove the backing and place the pads per the below instructions. Once the backing has been removed and the foam is attached to the wall it can not be removed without damage.

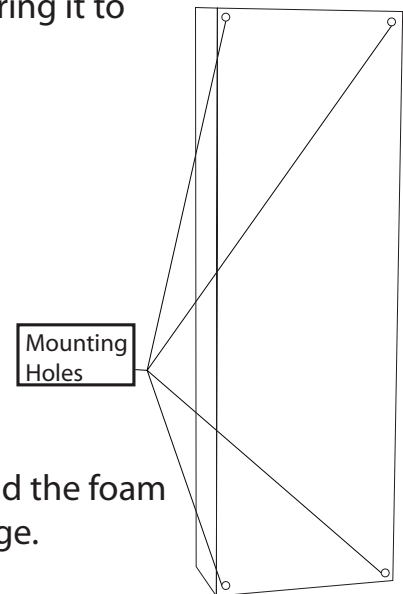
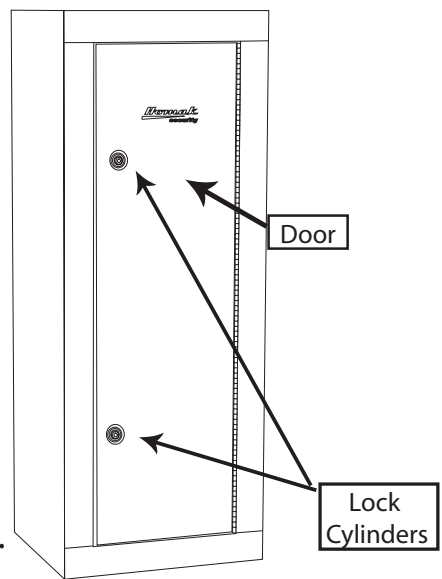

J

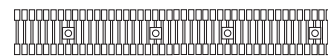

Barrel Rest Mounting Bar

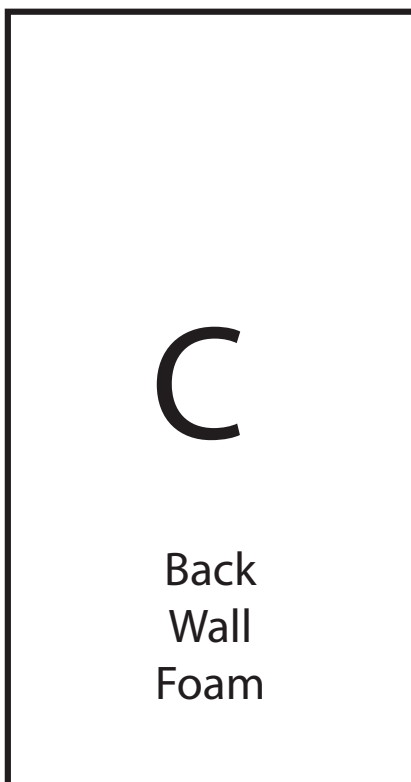

FOAM INSTALLATION

1. Decide the height that you will place the barrel rest. From this measurement cut the back wall foam into two pieces at the height that you will place the barrel rest. Any extra that is left may be placed above the barrel rest on the back wall.
2. Apply the foam liner (C) to the back of the cabinet by removing about 15" of paper at the bottom of (C), exposing the adhesive. Press the foam liner into place – starting $\frac{1}{2}$ " from the bottom of the cabinet. Continue to work upward, removing the paper and smoothing the foam into place as you go.
3. Remove the paper from barrel rest mounting bar (J) and place directly above (C) that was applied in step 2.
4. Place Bottom foam pad (B) into bottom of unit.

BARREL REST INSTALLATION

1. After the Barrel rest mounting bar has been attached during the Foam installation instructions, you may slide the barrel rests onto the mount bar in any position. They can be moved at any time.

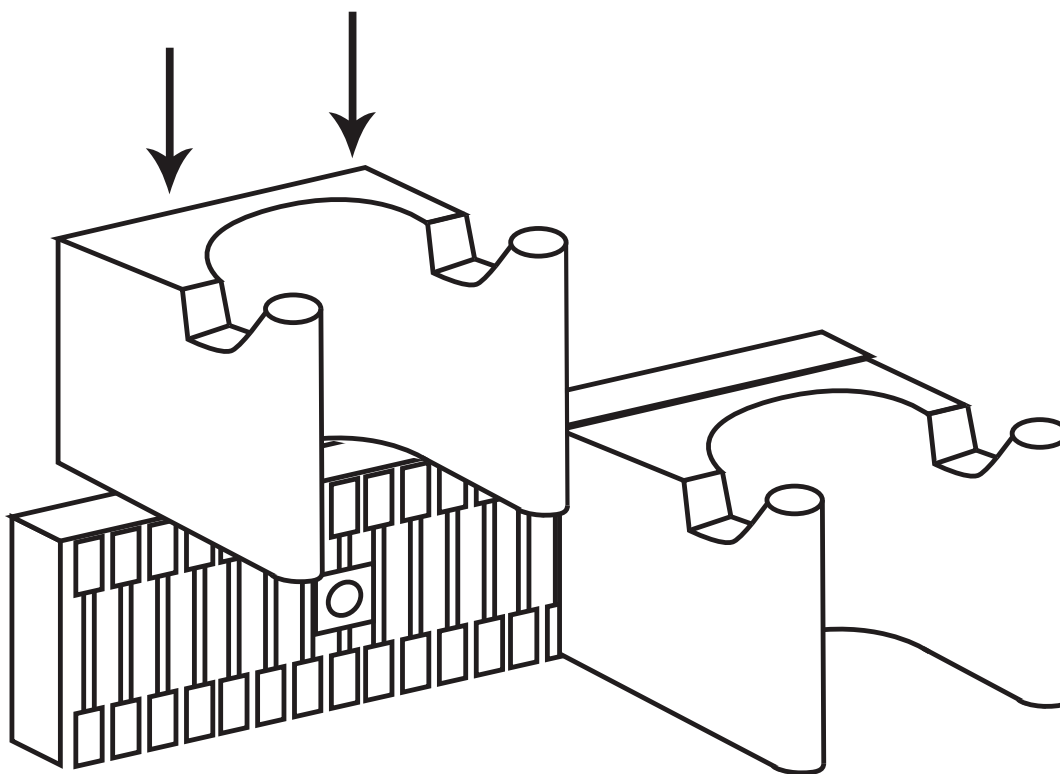

Homak has a full line of other security products, pistol boxes, and rifle cabinets. Visit our website at www.homakmfg.com

Features:

- All steel construction
- Thick powder coating finish to prevent metal corrosion
- Double strength edge on top door area to prevent pry bar entry
- "Piano" type hinges on full length of doors
- Quiet operation of door
- Large internal area allows for safe removal of firearm
- 4-point Locking Mechanism

Safety Precautions:

1. Keep from leaving a firearm loaded when securing it in this cabinet. Some types of weapons may discharge easily, and even though this cabinet is an all metal construction, a bullet may penetrate the steel wall.
2. Check and remove firearms contained in this cabinet before returning it to Homak or a Retail store. If the cabinet will not open, a certified locksmith may be able to open the cabinet with safe techniques.
3. Do not place this cabinet near excessive heat. This cabinet does not carry a fire rating.
4. If you misplace your keys, or need to purchase a replacement lock cylinder, contact Homak with the information below. Please have your key number ready which is located on some keys and is also stamped into the front of the lock cylinder.

PRODUCT REGISTRATION

Thank you for purchasing this quality HOMAK product. Please take the time to register your key and product by calling 1-800-874-6625 or by visiting www.homakmfg.com and clicking the "Product Registration" link.

This will allow us to better assist you in the future for:

- Replacement keys
- Parts
- Warranty claims
- Other product concerns

THIS PRODUCT CARRIES A LIMITED ONE (1) YEAR WARRANTY FOR PARTS AND LABOR

PLEASE CALL 1-800-874-6625 OR VISIT WWW.HOMAKMFG.COM FOR WARRANTY OR PART REPLACEMENT QUESTIONS.

Homak
security

Homak Manufacturing
1605 Old Route 18
Wampum, PA 16157

1-800-874-6625
www.homakmfg.com
PRODUCT MADE IN CHINA